

THIS TUB COMES IN THE FOLLOWING LINES

CLASSIC

DESIGNER

CAPRI J-16

65" X 40" X 23" END DRAIN



COMBO
HYDROTHERAPY

OVAL • 1 PERSON

OPERATING GALLONS
REGULAR USAGE - 40 GAL.



FEATURES

GENERAL

- High-gloss, High-impact, UV-resistant acrylic will not dull or fade
- Suitable for drop-in application
- Slip resistant bottom

WHIRLPOOL SYSTEM

- 5 flow-adjustable and directional jets, including:
 - 1 back jet
 - 2 side jets
 - 2 foot jets
- 1.5 B.H.P pump - 7.5 Amps
- Passive warm air induction system

AIR SYSTEM

- Seamless air injectors around tub perimeter
- Variable speed blower motor with 600 watt heater: 115 Volt - 10 Amps - 1 HP
- Mood light standard
- Electronic keypad control with variable speeds and 3 settings - Pulse, Wave, or Continuous

COMFORT

- Armrests
- Lumbar back support
- Totally insulated with eco-friendly polyurethane foam for a warmer bathing experience

CLEANLINESS

- Acrylic is easy to clean with standard non-abrasive household cleaning products
- Plumbed with anti-microbial flex piping
- Arched plumbing provides gravity flow draining for sanitary bathing
- Automatic purge keeps lines clean and dry

OPTIONS AVAILABLE

- LED light
- Tri-ssage control for pump flow rates
- Bath waste & overflows
- Spa Pillows
- Neck jet therapy system
- 6" acrylic grab bars
- Inline heater
- Extra jets/specialty jet upgrade

TRIM KIT FINISHES

- Polished chrome
- Satin nickel
- Oil rubbed bronze
- Polished brass

COLORS AVAILABLE

STANDARD COLORS

White, Biscuit

DECORATOR COLORS

Bone, Black, Ice Grey

WARRANTY

10-year limited factory warranty



Jetta guarantees that the water in our insulated whirlpool baths will stay within 2 degrees of its original fill temperature for 30 minutes of use without an inline heater.



J-16

Classic Collection **CAPRI**

JETTA COMBO HYDROTHERAPY | 65" X 40" X 23" | END DRAIN

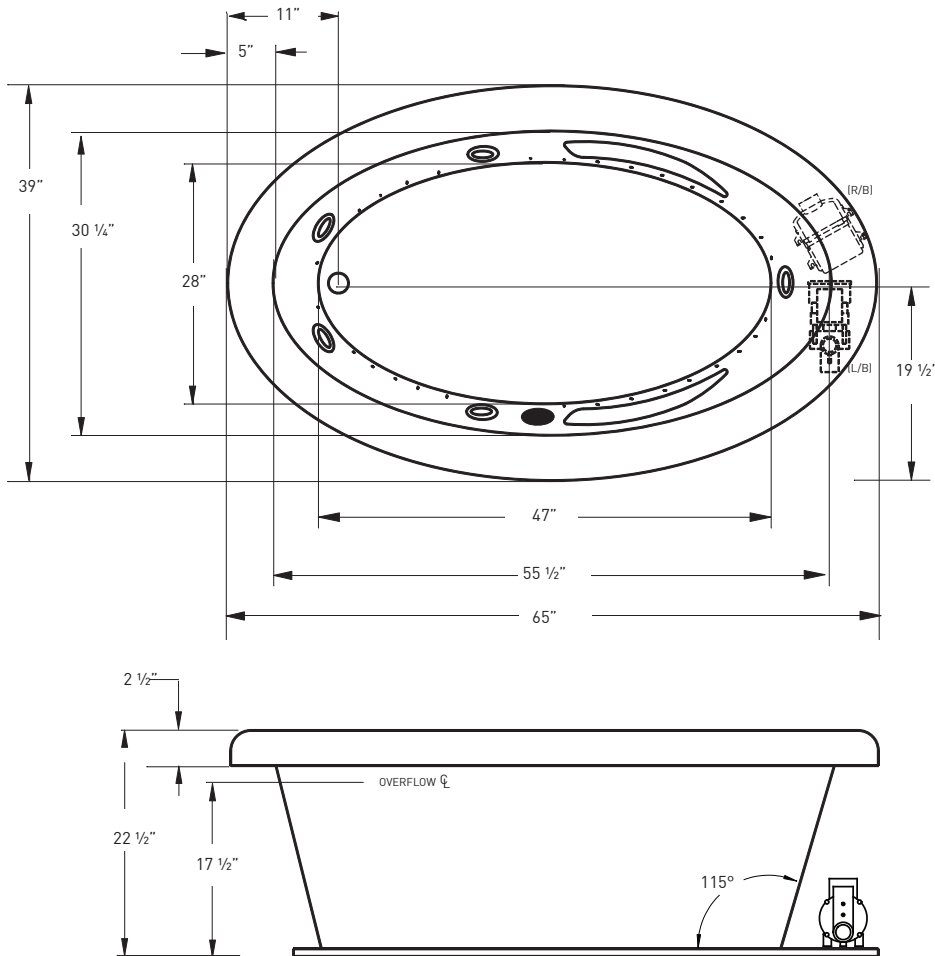

ELECTRICAL SPECIFICATIONS

Required Electrical Service 110/115 Volts
Standard Whirlpool 20 amp GFI
Standard Air 20 amp GFI
Each pump and blower must be protected by a dedicated GFI breaker (refer to local codes).

CODES/STANDARDS APPLICABLE

Specific model meets or exceeds the requirements for the following standards: ANSI, ASME

SUGGESTED PUMP & BLOWER ACCESS PANEL

Suggested access size 20" x 12"
Actual size may vary depending on distance of access to pump & blower location.

DROP-IN CUT OUT DIMENSIONS

Template provided with tub or upon request

SHIPPING WEIGHT 156 lbs

*L/B pump, R/B blower positions are standard.
Custom pump and blower locations available upon request.



INSTALLATION: MEASURE TUB BEFORE BUILDING TUB DECK.

For best results, Jetta Corporation recommends 1"-3" of mortar bedding under the tub base for maximum support. Drawing shows manufacturer's standard pump and blower location(s). Contact Jetta for details. Dimensional variance on drawings may be +/- 1/2 inch and are subject to change without notice.

JETTACORP.COM



© 2017 Jetta Corporation. All rights reserved. Specifications are subject to change without notice.
REV 06/2017

TECHNICAL SPECIFICATIONS